













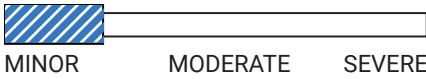

Display CARFAX in online listings:

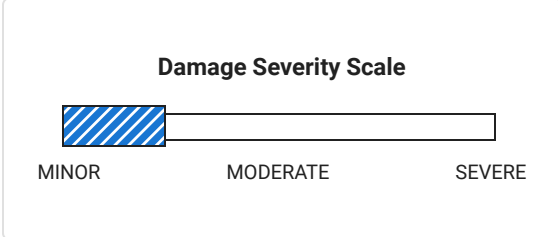
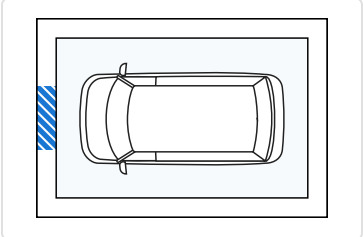

	This report provided free of charge by:	<b>5X TOP-RATED DEALER</b>	 <b>10,226</b> Customer Favorites
	<b>Van Bortel Ford</b> 71 Marsh Rd East Rochester, NY 14445 585-460-1438	 <b>4.8 / 5.0</b> 1,491 Verified Reviews	

	<b>Vehicle History Report™</b>	US \$44.99	
	<b>2011 HONDA ODYSSEY EX</b> VIN: 5FNRL5H4XBB056129 VAN 3.5L V6 F SOHC 24V GASOLINE FRONT WHEEL DRIVE	<b>Accident reported: minor damage</b>  	
This CARFAX Report Provided by: <b>Van Bortel Ford</b>  <b>4.8 / 5.0</b> 1,491 Verified Reviews  <b>10,226</b> Customer Favorites	 Regular oil changes		
	 At least 1 open recall		
	 CARFAX 1-Owner vehicle		
	 <b>171,219</b> Last reported odometer reading		

This CARFAX Vehicle History Report is based only on information supplied to CARFAX and available as of 7/9/24 at 2:40:27 PM (CDT). Other information about this vehicle, including problems, may not have been reported to CARFAX. Use this report as one important tool, along with a vehicle inspection and test drive, to make a better decision about your next used car.

	<b>Accident / Damage History</b> Not all accidents / issues are reported to CARFAX	
Event 1		
11/13/2018 <b>Accident reported: minor damage</b> - It hit a deer		

 <b>Additional History</b> Not all accidents / issues are reported to CARFAX	Owner 1
<b>Total Loss</b> No total loss reported to CARFAX.	<input checked="" type="checkbox"/> No Issues Reported
<b>Structural Damage</b> CARFAX recommends that you have this vehicle inspected by a collision repair specialist.	<input checked="" type="checkbox"/> No Issues Reported
<b>Airbag Deployment</b> No airbag deployment reported to CARFAX.	<input checked="" type="checkbox"/> No Issues Reported
<b>Odometer Check</b> No indication of an odometer rollback.	<input checked="" type="checkbox"/> No Issues Indicated
<b>Accident / Damage</b> Accident reported: 11/13/2018.	Minor Damage
<b>Manufacturer Recall</b> At least 1 manufacturer recall requires service. Locate an authorized Honda dealer to obtain more information about this recall.	Recall Reported
<b>Basic Warranty</b> Original warranty estimated to have expired.	Warranty Expired

 <b>Title History</b> CARFAX guarantees the information in this section	Owner 1
<b>Damage Brands</b> Salvage   Junk   Rebuilt   Fire   Flood   Hail   Lemon	<input checked="" type="checkbox"/> <b>Guaranteed</b> No Problem
<b>Odometer Brands</b> Not Actual Mileage   Exceeds Mechanical Limits	<input checked="" type="checkbox"/> <b>Guaranteed</b> No Problem
 <b>GUARANTEED</b> - None of these title problems were reported by a U.S. state Department of Motor Vehicles (DMV). If you find that any of these title problems were reported by a DMV and not included in this report, you may qualify. <a href="#">View Terms</a>   <a href="#">View Certificate</a>	

 <b>Ownership History</b> The number of owners is estimated	Owner 1
Year purchased	2011
Type of owner	Personal
Estimated length of ownership	13 yrs. 2 mo.
Owned in the following states/provinces	New York
Estimated miles driven per year	12,992/yr



Last reported odometer reading

171,219



## Detailed History

**Owner 1**





Purchased: 2011



**Low mileage!** This owner drove less than the industry average of 15,000 miles per year.

Personal Vehicle  
12,992 mi/yr

Date	Mileage	Source	Comments
03/14/2011	1	Ralph Honda Rochester, NY 585-225-3200 ralphdoneright.com ★ 4.7 / 5.0 74 Verified Reviews ♥ 7 Customer Favorites	<b>Vehicle serviced</b> - Pre-delivery inspection completed
03/14/2011	5	Ralph Honda Rochester, NY 585-225-3200 ralphdoneright.com ★ 4.7 / 5.0 74 Verified Reviews ♥ 7 Customer Favorites	<b>Vehicle offered for sale</b>
04/13/2011		Ralph Honda Rochester, NY 585-225-3200 ralphdoneright.com ★ 4.7 / 5.0 74 Verified Reviews ♥ 7 Customer Favorites	<b>Vehicle sold</b>
04/13/2011		Ralph Honda Rochester, NY 585-225-3200 ralphdoneright.com ★ 4.7 / 5.0 74 Verified Reviews ♥ 7 Customer Favorites	<b>Vehicle serviced</b> - Emissions or safety inspection performed
04/13/2011		New York Inspection Station	<b>Emissions inspection performed</b> - Dealer had vehicle inspected to prepare it for sale - Passed safety inspection
04/13/2011		New York Motor Vehicle Dept.	<b>Registration issued or renewed</b> - Titled or registered as personal vehicle

		Pittsford, NY		- Passed safety inspection
05/02/2011	684	Ralph Honda Rochester, NY 585-225-3200 ralphdoneright.com ★ 4.7 / 5.0 74 Verified Reviews ❤️ 7 Customer Favorites		<b>Vehicle serviced</b> - Wheels checked
05/04/2011		New York Motor Vehicle Dept. Pittsford, NY		<b>Title issued or updated</b> - First owner reported - Titled or registered as personal vehicle - Loan or lien reported
05/26/2011	1,474	Betten Baker Honda Muskegon, MI 231-755-3757 bettenbakerhonda.com ★ 4.7 / 5.0 167 Verified Reviews ❤️ 106 Customer Favorites		<b>Vehicle serviced</b>
08/09/2011	3,868	Betten Baker Honda Muskegon, MI 231-755-3757 bettenbakerhonda.com ★ 4.7 / 5.0 167 Verified Reviews ❤️ 106 Customer Favorites		<b>Vehicle serviced</b> - Maintenance inspection completed - Oil and filter changed
12/29/2011	9,934	Ralph Honda Rochester, NY 585-225-3200 ralphdoneright.com ★ 4.7 / 5.0 74 Verified Reviews ❤️ 7 Customer Favorites		<b>Vehicle serviced</b> - 10,000 mile service performed - Rear brakes serviced/adjusted - Fluids checked - Oil and filter changed - Tire condition and pressure checked - Tires rotated
04/04/2012	14,004	Ralph Honda Rochester, NY 585-225-3200 ralphdoneright.com ★ 4.7 / 5.0 74 Verified Reviews ❤️ 7 Customer Favorites		<b>Vehicle serviced</b> - Maintenance inspection completed - Fluids checked - Oil and filter changed - Emissions or safety inspection performed
04/04/2012		New York Inspection Station		<b>Passed safety inspection</b> - Emissions inspection performed
05/22/2012		New York Motor Vehicle Dept.		<b>Registration issued or renewed</b> - Titled or registered as personal vehicle

Pittsford, NY

- Passed safety inspection

07/17/2012 19,463

Betten Baker Honda  
Muskegon, MI  
231-755-3757  
bettenbakerhonda.com



**Vehicle serviced**

- Maintenance inspection completed
- Vehicle washed/detailed
- Oil and filter changed

★ 4.7 / 5.0

167 Verified Reviews

♥ 106 Customer Favorites

11/23/2012 25,863

Ralph Honda  
Rochester, NY  
585-225-3200  
ralphdoneright.com



**Vehicle serviced**

- Maintenance inspection completed
- Recommended maintenance performed
- 22,500 mile service performed
- Battery/charging system checked
- Fluids checked
- Oil and filter changed
- Tire condition and pressure checked
- Tires rotated

★ 4.7 / 5.0

74 Verified Reviews

♥ 7 Customer Favorites

04/01/2013 30,946

Ralph Honda  
Rochester, NY  
585-225-3200  
ralphdoneright.com



**Vehicle serviced**

- Recommended maintenance performed
- 30,000 mile service performed
- Tire repaired
- Safety inspection performed
- Tire condition and pressure checked
- Cabin air filter replaced/cleaned
- Emissions inspection performed

★ 4.7 / 5.0

74 Verified Reviews

♥ 7 Customer Favorites

04/01/2013

New York  
Inspection Station

**Passed safety inspection**

- Passed emissions inspection

06/11/2013 36,194

Ralph Honda  
Rochester, NY  
585-225-3200  
ralphdoneright.com



**Vehicle serviced**

- Maintenance inspection completed
- Fluids checked
- Oil and filter changed
- Tire condition and pressure checked
- Tires rotated

★ 4.7 / 5.0

74 Verified Reviews

♥ 7 Customer Favorites

01/02/2014 44,312

Ralph Honda  
Rochester, NY  
585-225-3200  
ralphdoneright.com



**Vehicle serviced**

- Maintenance inspection completed
- Recommended maintenance performed
- 45,000 mile service performed
- Air filter checked
- PCV valve replaced
- Parking brake adjusted
- Brakes checked
- Oil and filter changed
- Tire condition and pressure checked
- Tires rotated

★ 4.7 / 5.0

74 Verified Reviews

♥ 7 Customer Favorites

- Drain plug gasket replaced

01/09/2014 44,414

Dunn Tire  
Rochester, NY  
585-203-1140  
dunntire.com

★ 4.8 / 5.0

180 Verified Reviews

♥ 40 Customer Favorites



**Vehicle serviced**

- Tire(s) replaced
- Four tires replaced
- Alignment checked

04/03/2014 46,678

Schoen Place Auto  
East Rochester, NY  
585-381-1970  
schoenplaceauto.com

★ 5.0 / 5.0

82 Verified Reviews

♥ 21 Customer Favorites



**Vehicle serviced**

- Safety inspection performed
- Emissions inspection performed
- Emissions or safety inspection performed

04/03/2014

New York  
Inspection Station

**Passed safety inspection**

- Emissions inspection performed

05/20/2014

New York  
Motor Vehicle Dept.  
Pittsford, NY

**Registration issued or renewed**

- Titled or registered as personal vehicle
- Passed safety inspection

06/20/2014 50,050

Schoen Place Auto  
East Rochester, NY  
585-381-1970  
schoenplaceauto.com

★ 5.0 / 5.0

82 Verified Reviews

♥ 21 Customer Favorites



**Vehicle serviced**

- Maintenance inspection completed
- Air filter checked
- Oil and filter changed
- Steering/suspension lubricated
- Fluids checked
- Body lubricated
- Battery/charging system checked

11/13/2014 57,938

Schoen Place Auto  
East Rochester, NY  
585-381-1970  
schoenplaceauto.com

★ 5.0 / 5.0

82 Verified Reviews

♥ 21 Customer Favorites



**Vehicle serviced**

- Maintenance inspection completed
- Air filter checked
- Oil and filter changed
- Brake fluid flushed/changed
- Brake fluid checked
- Steering/suspension lubricated
- Fluids checked
- Body lubricated
- Battery/charging system checked
- Brakes checked
- Front wiper blades/refills replaced
- Cabin air filter replaced/cleaned

01/28/2015 60,991

Schoen Place Auto  
East Rochester, NY  
585-381-1970  
schoenplaceauto.com

★ 5.0 / 5.0

82 Verified Reviews



**Vehicle serviced**

- Drivability/performance checked
- Tire pressure sensor replaced
- Tire pressure sensor checked

 21 Customer Favorites

04/23/2015 65,371

Schoen Place Auto  
East Rochester, NY  
585-381-1970  
schoenplaceauto.com

 5.0 / 5.0

82 Verified Reviews

 21 Customer Favorites



**Vehicle serviced**

- Maintenance inspection completed
- Oil and filter changed
- Tires rotated
- Air filter checked
- Tire condition and pressure checked
- Steering/suspension lubricated
- Fluids checked
- Body lubricated
- Battery/charging system checked

04/23/2015

New York  
Inspection Station

**Passed safety inspection**

- Passed emissions inspection

08/25/2015 70,965

Schoen Place Auto  
East Rochester, NY  
585-381-1970  
schoenplaceauto.com

 5.0 / 5.0

82 Verified Reviews

 21 Customer Favorites



**Vehicle serviced**

- Oil and filter changed
- Fluids checked
- Tire condition and pressure checked

11/13/2015 75,004

Schoen Place Auto  
East Rochester, NY  
585-381-1970  
schoenplaceauto.com

 5.0 / 5.0

82 Verified Reviews

 21 Customer Favorites



**Vehicle serviced**

- Oil and filter changed
- Air filter replaced
- Fluids checked
- Tire condition and pressure checked

05/16/2016 83,034

Schoen Place Auto  
East Rochester, NY  
585-381-1970  
schoenplaceauto.com

 5.0 / 5.0

82 Verified Reviews

 21 Customer Favorites



**Vehicle serviced**

- Oil and filter changed
- Safety inspection performed
- Emissions inspection performed

05/19/2016

New York  
Inspection Station

**Passed safety inspection**

- Passed emissions inspection

06/02/2016

Schoen Place Auto  
East Rochester, NY  
585-381-1970  
schoenplaceauto.com

 5.0 / 5.0

82 Verified Reviews

 21 Customer Favorites



**Vehicle serviced**

- Rear brake pads replaced
- Brake fluid flushed/changed
- Rear brake rotor(s) replaced
- Brakes serviced
- Brake fluid checked
- Drivability/performance checked
- Brakes checked

06/07/2016

New York

**Registration issued or renewed**

Motor Vehicle Dept.  
Pittsford, NY

- Titled or registered as personal vehicle  
- Passed safety inspection

11/16/2016 91,565

Schoen Place Auto  
East Rochester, NY  
585-381-1970  
schoenplaceauto.com



**Vehicle serviced**

- Oil and filter changed

★ 5.0 / 5.0

82 Verified Reviews

♥ 21 Customer Favorites

11/25/2016

Dunn Tire  
Rochester, NY  
585-203-1140  
dunntire.com



**Vehicle serviced**

- Tire(s) replaced  
- Four tires replaced

★ 4.8 / 5.0

180 Verified Reviews

♥ 40 Customer Favorites

12/21/2016

American Honda Motor  
Co.

**Manufacturer Safety-related recall issued**

- NHTSA #16V-933  
- Recall #KD5 2nd Row Walk-In Function Inop  
- Status: Remedy Available

Locate an authorized Honda dealer to obtain more information about this recall

⊖ [Learn more about this recall](#)

**Description:** AMERICAN HONDA MOTOR CO., INC. (HONDA) IS RECALLING CERTAIN MODEL YEAR 2011-2016 ODYSSEY VEHICLES. THE SECOND ROW OUTBOARD SEATS INSTALLED IN AFFECTED VEHICLES HAVE A RELEASE LEVER FOR THE WALK-IN FEATURE WHICH FOLDS THE SEATBACK AND SLIDES THE SEAT FORWARD FOR ACCESS TO THE THIRD ROW SEAT. DUE TO SEAT COMPONENT MANUFACTURING AND ASSEMBLY ERRORS, THERE IS POTENTIAL FOR THE SEAT TO STAY IN THE UNLOCKED POSITION AFTER RETURNING THE SEAT TO ITS NORMAL SEATING POSITION, WHICH WOULD ALLOW THE SEAT TO SLIDE FORWARD OR REARWARD WITHOUT WARNING.

AN UNLOCKED SECOND ROW OUTBOARD SEAT INCREASES THE RISK OF INJURY TO THE SEAT OCCUPANT DURING A CRASH.

**Remedy:** HONDA WILL NOTIFY OWNERS, AND DEALERS WILL INSTALL ADDITIONAL BRACKETS AND SPRINGS TO BOTH SECOND ROW OUTBOARD SEATS, FREE OF CHARGE. OWNERS MAY CONTACT HONDA AUTOMOBILE CUSTOMER SERVICE AT 1-888-234-2138. HONDA'S NUMBER FOR THIS RECALL IS KD5.

05/19/2017 99,174

Schoen Place Auto  
East Rochester, NY  
585-381-1970  
schoenplaceauto.com



**Vehicle serviced**

- Maintenance inspection completed  
- Rear brake pads replaced  
- Oil and filter changed  
- Safety inspection performed  
- Fluids checked

★ 5.0 / 5.0



82 Verified Reviews

 21 Customer Favorites

- Tire condition and pressure checked
- Brakes checked
- Emissions or safety inspection performed

05/25/2017

New York  
Inspection Station

**Passed safety inspection**

- Passed emissions inspection

08/31/2017 104,100

Sears Auto Center  
Victor, NY  
585-421-3395  
searsauto.com



**Vehicle serviced**

- Maintenance inspection completed
- Battery replaced

 4.8 / 5.0

21 Verified Reviews

11/03/2017 106,137

Schoen Place Auto  
East Rochester, NY  
585-381-1970  
schoenplaceauto.com



**Vehicle serviced**

- Maintenance inspection completed
- Oil and filter changed
- Wiper(s) replaced
- Fluids checked
- Tire condition and pressure checked

 5.0 / 5.0

82 Verified Reviews

 21 Customer Favorites

03/07/2018

American Honda Motor  
Co.

**Manufacturer Safety-related recall issued**

- NHTSA #17V-725
- Recall #P0Q 2nd Row Outer Seat Striker Bracket (Seat Tipping)
- Status: Remedy Available

Locate an authorized Honda dealer to obtain more information about this recall

 [Learn more about this recall](#)

**Description:** American Honda Motor Co., inc. (Honda) is recalling certain model year 2011 - 2017 Odyssey vehicles. The second row outer (outboard) seats can be placed in two positions, standard and wide. When installing or repositioning the seat into either position, it is possible that the rear latch may not attach properly to the correct position on the seat striker.

An unlatched second row outer seat could tip forward during moderate to heavy braking increasing the risk of injury to an occupant, including a child seated in a LATCH child seat.

**Remedy:** Honda will notify owners in an interim notification that the parts necessary to repair their vehicles are currently not available. Included in the interim notification will be detailed instructions for installing/positioning second row outer seats and confirming that they are securely latched. These instructions can also be viewed on [www.recalls.honda.com](http://www.recalls.honda.com). Honda will send a second notification to owners when parts become available to repair their vehicles and dealers will install a bracket to the second row forward outboard floor strikers to prevent improper seat positioning, apply a warning label to the second row outboard seats and provide an updated owners information card for free. For additional questions or to get help locating a dealer, owners may contact American

Honda's Customer Support & Campaign Center at 1-888-234-2138. Honda's number for this recall is P0Q.

05/14/2018 112,355 Schoen Place Auto  
East Rochester, NY  
585-381-1970  
schoenplaceauto.com  
★ 5.0 / 5.0  
82 Verified Reviews  
♥ 21 Customer Favorites



**Vehicle serviced**

- Maintenance inspection completed
- Fluids checked
- Oil and filter changed
- Tire condition and pressure checked

05/14/2018 New York  
Inspection Station

**Passed safety inspection**

- Passed emissions inspection

05/31/2018 New York  
Motor Vehicle Dept.  
Pittsford, NY

**Registration issued or renewed**

- Titled or registered as personal vehicle
- Passed safety inspection

06/04/2018 113,060 Schoen Place Auto  
East Rochester, NY  
585-381-1970  
schoenplaceauto.com  
★ 5.0 / 5.0  
82 Verified Reviews  
♥ 21 Customer Favorites



**Vehicle serviced**

- Timing belt replaced
- Antifreeze/coolant flushed/changed

10/01/2018 119,772 Schoen Place Auto  
East Rochester, NY  
585-381-1970  
schoenplaceauto.com  
★ 5.0 / 5.0  
82 Verified Reviews  
♥ 21 Customer Favorites



**Vehicle serviced**

- Fluids checked
- Oil and filter changed
- Tire condition and pressure checked

11/13/2018 Damage Report



**Accident reported: minor damage**

- It hit a deer
- Damage to front

**Damage Severity Scale**

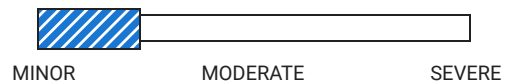

**Damage Location**

FRONT

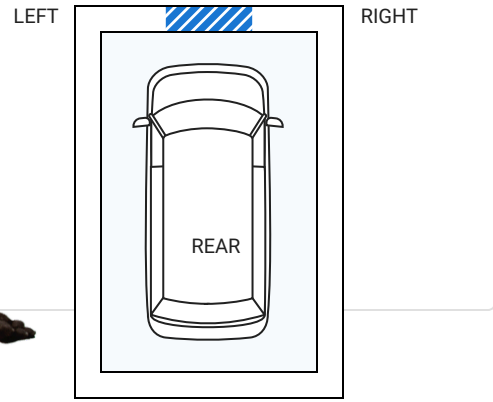

## CARFAX HAS THE MOST ACCIDENT & DAMAGE INFORMATION



Minor damage is usually cosmetic, including dents or scratches to the vehicle body.

05/02/2019 125,763

Schoen Place Auto  
East Rochester, NY  
585-381-1970  
schoenplaceauto.com

★ 5.0 / 5.0

82 Verified Reviews

♥ 21 Customer Favorites



### Vehicle serviced

- Oil and filter changed
- Front brake rotor(s) replaced
- Fluids checked
- Tire condition and pressure checked
- Drivability/performance checked
- Front brake pads replaced
- Brake fluid checked
- Brakes serviced

05/02/2019

New York  
Inspection Station

### Passed safety inspection

- Passed emissions inspection

06/10/2019 127,286

Dunn Tire  
Rochester, NY  
585-203-1140  
dunntire.com

★ 4.8 / 5.0

180 Verified Reviews

♥ 40 Customer Favorites









### Vehicle serviced

- Alignment checked
- Tires rotated

09/20/2019

New York  
Motor Vehicle Dept.  
Pittsford, NY

**Registration updated when owner moved the vehicle to a new location**

10/24/2019	132,436	Schoen Place Auto East Rochester, NY 585-381-1970 schoenplaceauto.com ★ 5.0 / 5.0 82 Verified Reviews ❤️ 21 Customer Favorites	 <b>Vehicle serviced</b> - Oil and filter changed - Fluids checked - Tire condition and pressure checked
06/11/2020	136,540	Schoen Place Auto East Rochester, NY 585-381-1970 schoenplaceauto.com ★ 5.0 / 5.0 82 Verified Reviews ❤️ 21 Customer Favorites	 <b>Vehicle serviced</b> - Rear brake rotor(s) replaced - Lower ball joint(s) replaced - Brakes serviced - Drivability/performance checked - Rear brake pads replaced - Brake fluid checked
06/11/2020		New York Inspection Station	<b>Passed safety inspection</b> - Passed emissions inspection
06/18/2020		New York Motor Vehicle Dept. Pittsford, NY	<b>Registration issued or renewed</b> - Titled or registered as personal vehicle - Passed safety inspection
09/15/2020	138,938	Schoen Place Auto East Rochester, NY 585-381-1970 schoenplaceauto.com ★ 5.0 / 5.0 82 Verified Reviews ❤️ 21 Customer Favorites	 <b>Vehicle serviced</b> - Fluids checked - Oil and filter changed - Tire condition and pressure checked
11/12/2020	141,041	Dunn Tire Rochester, NY 585-203-1140 dunntire.com ★ 4.8 / 5.0 180 Verified Reviews ❤️ 40 Customer Favorites	 <b>Vehicle serviced</b> - Tire(s) replaced - Four tires replaced
05/21/2021	145,769	Schoen Place Auto East Rochester, NY 585-381-1970 schoenplaceauto.com ★ 5.0 / 5.0 82 Verified Reviews ❤️ 21 Customer Favorites	 <b>Vehicle serviced</b> - Oil and filter changed - Fluids checked - Tire condition and pressure checked
06/10/2021	146,271	Schoen Place Auto East Rochester, NY 585-381-1970 schoenplaceauto.com	 <b>Vehicle serviced</b> - Fluids checked - Power steering pump replaced

★ 5.0 / 5.0  
82 Verified Reviews  
♥ 21 Customer Favorites

06/10/2021

New York  
Inspection Station

**Passed safety inspection**  
- Passed emissions inspection

12/16/2021 151,516

Schoen Place Auto  
East Rochester, NY  
585-381-1970  
schoenplaceauto.com



**Vehicle serviced**  
- Oil and filter changed  
- Serpentine belt replaced  
- Alternator checked  
- Fluids checked  
- Tire condition and pressure checked

★ 5.0 / 5.0  
82 Verified Reviews  
♥ 21 Customer Favorites

06/06/2022

New York  
Motor Vehicle Dept.  
Pittsford, NY

**Registration issued or renewed**  
- Titled or registered as personal vehicle  
- Passed safety inspection

07/11/2022 156,509

Schoen Place Auto  
East Rochester, NY  
585-381-1970  
schoenplaceauto.com



**Vehicle serviced**

★ 5.0 / 5.0  
82 Verified Reviews  
♥ 21 Customer Favorites

07/11/2022

New York  
Inspection Station

**Passed safety inspection**  
- Passed emissions inspection

08/23/2022 157,807

Schoen Place Auto  
East Rochester, NY  
585-381-1970  
schoenplaceauto.com



**Vehicle serviced**  
- Rear shock absorber(s) replaced  
- Oil and filter changed  
- Fluids checked  
- Tire condition and pressure checked

★ 5.0 / 5.0  
82 Verified Reviews  
♥ 21 Customer Favorites

12/20/2022 160,610

Schoen Place Auto  
East Rochester, NY  
585-381-1970  
schoenplaceauto.com



**Vehicle serviced**  
- Sway bar link(s) replaced  
- Battery replaced  
- Drivability/performance checked  
- Battery/charging system checked

★ 5.0 / 5.0  
82 Verified Reviews  
♥ 21 Customer Favorites

06/08/2023 163,763

Schoen Place Auto  
East Rochester, NY  
585-381-1970  
schoenplaceauto.com



**Vehicle serviced**  
- Oil and filter changed  
- Fluids checked  
- Tire condition and pressure checked  
- Rear brake rotor(s) replaced  
- Alignment checked

★ 5.0 / 5.0  
82 Verified Reviews

♥ 21 Customer Favorites

- Steering/suspension checked
- Alignment performed
- Drivability/performance checked
- Brake fluid checked
- Rear brake pads replaced
- Control arm(s) replaced
- Brakes serviced
- Air filter replaced
- Cabin air filter replaced/cleaned

06/13/2023 163,991 New York  
Inspection Station

**Passed safety inspection**  
- Passed emissions inspection

05/29/2024 New York  
Motor Vehicle Dept.  
Pittsford, NY

**Registration issued or renewed**  
- Titled or registered as personal vehicle  
- Passed safety inspection

06/13/2024 171,219 Valvoline Instant Oil  
Change  
Henrietta, NY  
585-427-8001  
vioc.com



**Vehicle serviced**  
- Oil and filter changed

★ 4.6 / 5.0

309 Verified Reviews

♥ 374 Customer Favorites



This vehicle's oil change history, as reported to CARFAX, aligns with oil changes reported on other 2011 Honda Odyssey EX vehicles - approximately every 7,500 miles. Track your service history for free at [carfax.com/service](https://www.carfax.com/service).

Have Questions? Consumers, please visit our Help Center at [www.carfax.com](https://www.carfax.com). Dealers or Subscribers, please visit our Help Center at [www.carfaxonline.com](https://www.carfaxonline.com).



## Glossary

### Accident Indicator

CARFAX receives information about accidents in all 50 states, the District of Columbia and Canada.

Not every accident is reported to CARFAX. As details about the accident become available, those additional details are added to the CARFAX Vehicle History Report. CARFAX recommends that you have this vehicle inspected by a qualified mechanic.

- According to the National Safety Council, Injury Facts, 2021 edition, 5% of the 276 million registered vehicles in the U.S. were involved in an accident in 2019. Over 77% of these were considered minor or moderate.
- This CARFAX Vehicle History Report is based only on information supplied to CARFAX and available as of 7/9/24 at 2:40:27 PM (CDT). Other information about this vehicle, including problems, may not have been reported to CARFAX. Use this report as one important tool, along with a vehicle inspection and test drive, to make a better decision about your next used car.

### CARFAX Well Maintained - Regular Oil Changes

CARFAX identifies a "Well Maintained - Regular Oil Change" vehicle as having a regular oil change history when all its recommended oil changes, based on the vehicle's maintenance schedule, have been reported to CARFAX. CARFAX

uses the manufacturer's schedule and assumes normal driving conditions. When an oil change schedule is not available, CARFAX may analyze reported service events to determine what is typical for the same make and model vehicle. Dealers and service shops may publish different recommended service schedules.

### Damage Severity

Damage events result in one of the following severity levels:

- **Minor:** Generally, minor damage is cosmetic (including dents or scratches), may only require reconditioning, and typically does not compromise a vehicle's operation and/or safety.
- **Moderate:** Moderate damage may affect multiple components of the vehicle and may impair the vehicle's operation and/or safety.
- **Severe:** Severe damage usually affects multiple components of the vehicle and is likely to compromise the vehicle's operation and/or safety.

CARFAX recommends getting a pre-purchase inspection at a certified collision repair facility.

### First Owner

When the first owner(s) obtains a title from a Department of Motor Vehicles as proof of ownership.

### Inspections

Many states or counties require annual or biennial emissions and/or safety inspections. Odometer readings are collected at the time of the inspection.

### Manufacturer Recall

Automobile manufacturers issue recall notices to inform vehicle owners of a safety defect or failure to meet minimum federal safety or emissions standards. Manufacturer recalls are repaired at no cost to the customer.

### Ownership History

CARFAX defines an owner as an individual or business that possesses and uses a vehicle. Not all title transactions represent changes in ownership. To provide estimated number of owners, CARFAX proprietary technology analyzes all the events in a vehicle history. Estimated ownership is available for vehicles manufactured after 1991 and titled solely in the US including Puerto Rico. Dealers sometimes opt to take ownership of a vehicle and are required to in the following states: Maine, Massachusetts, New Jersey, Ohio, Oklahoma, Pennsylvania and South Dakota. Please consider this as you review a vehicle's estimated ownership history.

### Title Issued

A state issues a title to provide a vehicle owner with proof of ownership. Each title has a unique number. Each title or registration record on a CARFAX report does not necessarily indicate a change in ownership. In Canada, a registration and bill of sale are used as proof of ownership.

Follow Us:



[facebook.com/CARFAX](https://facebook.com/CARFAX)



[@CARFAXinc](https://twitter.com/CARFAXinc)



About CARFAX

CARFAX DEPENDS ON ITS SOURCES FOR THE ACCURACY AND RELIABILITY OF ITS INFORMATION. THEREFORE, NO RESPONSIBILITY IS ASSUMED BY CARFAX OR ITS AGENTS FOR ERRORS OR OMISSIONS IN THIS REPORT. CARFAX FURTHER EXPRESSLY DISCLAIMS ALL WARRANTIES, EXPRESS OR IMPLIED, INCLUDING ANY IMPLIED WARRANTIES OF MERCHANTABILITY OR FITNESS FOR A PARTICULAR PURPOSE.

© 2024 CARFAX, Inc., part of S&P Global. All rights reserved.  
7/9/24 2:40:27 PM (CDT)

**I have reviewed and received a copy of the CARFAX Vehicle History Report for this 2011 HONDA ODYSSEY vehicle (VIN: 5FNRL5H4XBB056129), which is based on information supplied to CARFAX and available as of 7/9/24 at 3:40 PM (EDT).**

Customer Signature

Date

Dealer Signature

Date